



MOULTRIE®

Instructions for All In One Timer Feeder

THANK YOU for your purchase of the All-In-One Timer Feeder. Please read this sheet before operating the unit. If you should have any questions about this product or any other Moultrie product, please contact us using the information on the back of this sheet. To help us to better serve you, please submit your Warranty information online at <http://www.moultriefeeders.com/warranty>

A1 PURCHASED WITH EXPANDABLE BUCKET

Expand feeder by pulling firmly on both ends until sections click and lock permanently into place.

If sections do not lock into place, confirm that the internal alignment ribs are in the correct position. Remove the lid and look down inside bucket. Verify that the vertical ribs along the side are aligned with the small notches located in the top of each section.

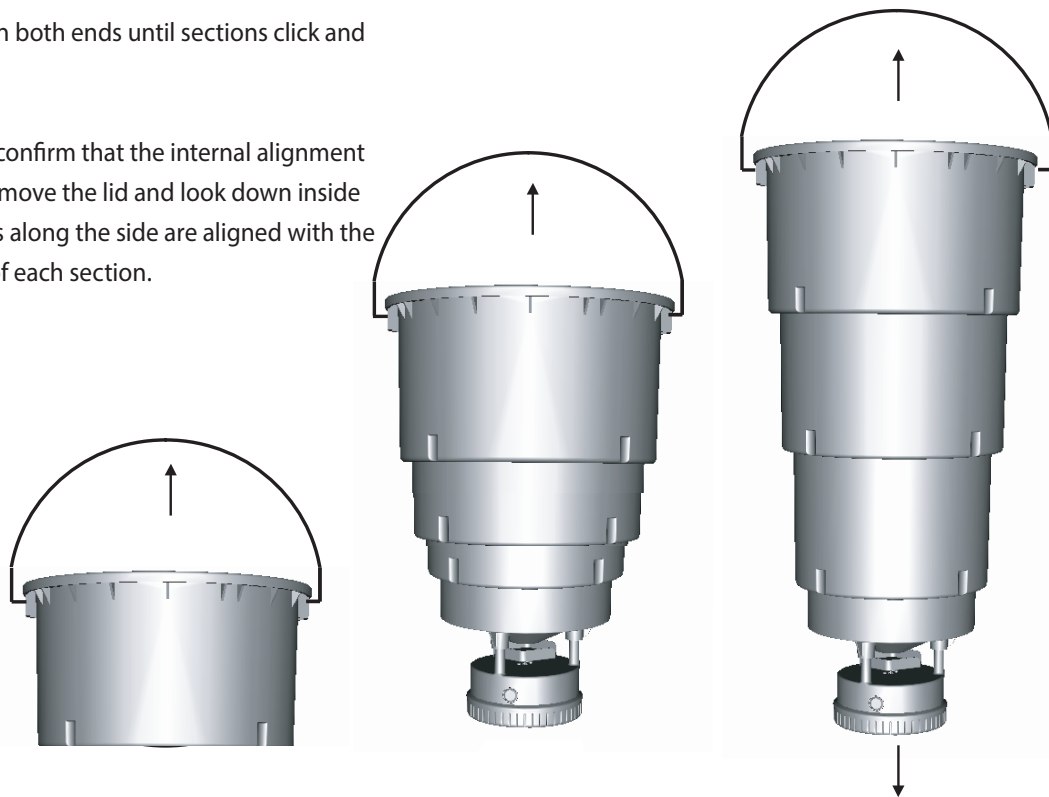

A2 PURCHASED WITHOUT EXPANDABLE BUCKET

 **CAUTION: WEAR EYE PROTECTION**

The All-In-One Feeder will mount to any drum or bucket.

- 1** Turn bucket over, measure and mark the center of the bottom.
- 2** Center the provided template on the bottom of the bucket and secure with tape. Percez trois trous de montage du chargeur de 8 mm.
- 3** Using a hole saw, drill a 2-1/4" hole in the center of the bottom of your bucket.
- 4** Rotate the mounts outward on the feeder mounting bracket. Attach feeder to bucket using three provided 1/4"-20 x 1" bolts, washers and nuts as shown.

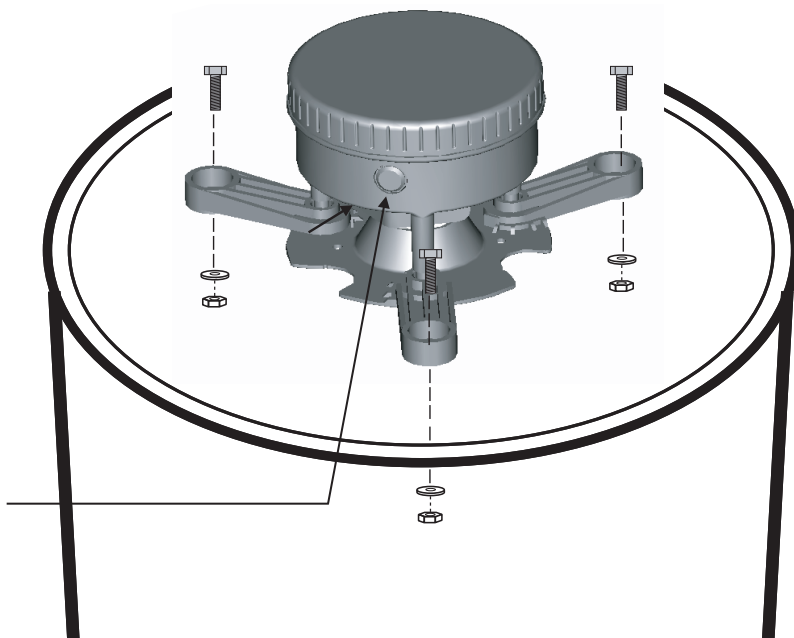
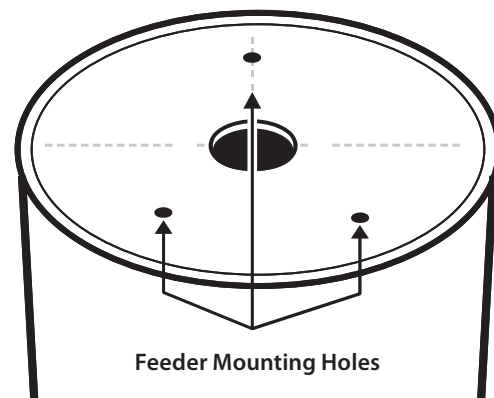

Solar Panel Receptacle

The Moultrie Solar Panel upgrade (MFA-12602 or MFHP12349) may greatly extend battery life and may be purchased at a Moultrie distributor or by visiting moultriefeeders.com

NOTE: Make sure to insert rechargeable batteries before attaching solar panel.

B INSTALL BATTERIES



CAUTION: WEAR EYE PROTECTION

To install the batteries or adjust the feed settings, remove the bottom of the feeder by rotating it counter clockwise as shown. Install four (4) AA alkaline or lithium batteries with the negative side of the battery going to the battery holder spring clip. Replace bottom by rotating clockwise until secure.

NOTE: Do not mix old and new batteries.
Always replace ALL the batteries at the same time.
Do not mix battery types.
If using solar panel, insert rechargeable batteries.

Rotate counter-clockwise to open

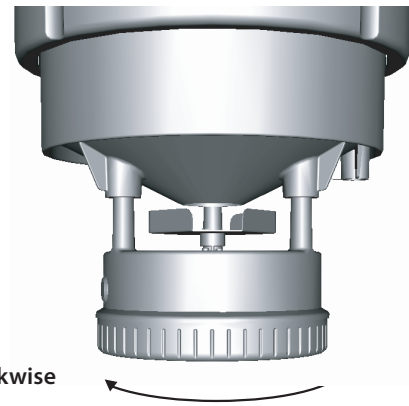

C CONFIGURING AND TESTING FEEDER

Your feeder will feed up to four times per day and has been factory set to feed at 7:00am and 6:00pm for 6 seconds. To change factory settings or add additional feed times, follow the instructions below.

- 1 POSITION TIMER:** The timer may be rotated outward for easier viewing. Gently pull down on the button-side of the timer as shown.

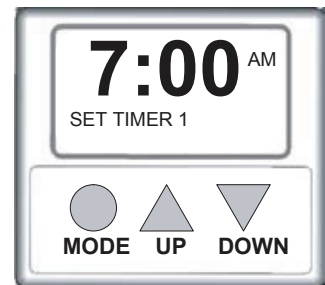
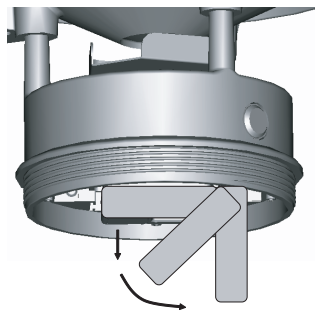

- 2 SET TIME OF DAY:** Press the UP or DOWN button until the correct time of day appears. Press and release button to single-step through the minutes or hold down to advance quickly.

- 3 SET FEED TIMES:** Press the SET button until the correct timer number appears in the upper right hand corner as shown. Press the UP or DOWN button to set the Feed Time. **Note: Factory settings are 7am and 6pm.**

- 4 SET RUN DURATION:** Press the SET button again to set the RUN-TIME SECONDS which can range from zero to twenty seconds. Adjust RUN-TIME SECONDS using the chart below. Set the RUN-TIME SECONDS to zero to disable the specific feed time. **Note: Factory setting is 6 seconds.**

| RUN TIME (sec.) | 4 | 6 | 8 | 10 | 12 | 14 | 16 | 18 | 20 |
|-------------------------------|-----|-----|-----|-----|-----|-----|-----|-----|-----|
| Approx. Feed Dispensed (lbs.) | 1.0 | 1.5 | 1.9 | 2.4 | 2.8 | 3.3 | 3.7 | 4.2 | 4.6 |

TEST FEEDER: PRESS AND HOLD the SET button while the RUN-TIME SECONDS are displayed. Release the button and get away from the feeder when the message "TESTING GET AWAY" appears on the display.

Battery Information:

- Do Not Mix Old and New Batteries
- Do Not Mix Alkaline, Standard, or Rechargeable Batteries

FCC COMPLIANCE

This device complies with part 15 of the FCC Rules. Operation is subject to the following two conditions: (1) This device may not cause harmful interference, and (2) this device must accept any interference received, including interference that may cause undesired operation.

For devices approved under Part 15, the user's manual or instruction manual for an intentional or unintentional radiator shall caution the user about changes or modifications to the device (Section 15.21).

NOTE: This equipment has been tested and found to comply with the limits for a Class B digital device, pursuant to part 15 of the FCC Rules. These limits are designed to provide reasonable protection against harmful interference in a residential installation. This equipment generates, uses and can radiate radio frequency energy and, if not installed and used in accordance with the instructions, may cause harmful interference to radio communications. However, there is no guarantee that interference will not occur in a particular installation. If this equipment does cause harmful interference to radio or television reception, which can be determined by turning the equipment off and on, the user is encouraged to try to correct the interference by one or more of the following measures:

- Reorient or relocate the receiving antenna.
- Increase the separation between the equipment and receiver.
- Connect the equipment into an outlet on a circuit different from that to which the receiver is connected.
- Consult the dealer or an experienced radio/TV technician for help.

MOULTRIE®

Our Service Department will gladly answer any questions you have.
www.moultriefeeders.com/support

09142020 / MFH-ATK / MFH-AT5